

PM MAXIMUM TRUSS

Meet the ultimate truss adapter, the **PP-TA2**, is engineered to eliminate limitations and elevate your display installations. Designed for professionals who demand flexibility, strength, and speed, this mount adapts seamlessly to virtually any truss configuration, making it the go-to solution for all rental and staging applications.

FEATURES + BENEFITS

- Universal go-to solution for all rental and staging truss applications
- Fast, Tool-Light installation
- Mounts to truss system vertically, horizontally and overhead
- Heavy-Duty Steel Construction
- Portrait and Landscape Support
- Supports single and multiple display applications



PRODUCT SPECS	
PART #	PP-TA2
PRODUCT WEIGHT	9 lbs 4.08kg
WIDTH	16.25 in 41.28 cm
HEIGHT	7.23 in 18.36 cm
DEPTH	3.88 in 9.86 cm
WEIGHT RATING	Up to 200 lbs per PP-TA2 (Refer to weight capacities of mounting solution)



COMPATIBILITY CHART



COMPATIBILITY	HORIZONTAL	VERTICAL	OVERHEAD	WEIGHT CAPACITY
CTM-MS1, CTM-MS2, PFDM2, PTDM2	✓	✓		160 lbs
PP-5, PP-5A, PP-6A, AST-1321, AST-2446, PBC-UMS, PBC-UMW, PBL-UMS, PBL-UMW, PBM-UNI			✓	200 lbs
Display Panel (75X75), UFP-280B, UFP-400	✓	✓		50 lbs
SYM-IB-XXX (Symmetry Interface Bar Requires Two PP-TA2)	✓			300 lbs
CTM-MS3 (Requires Two PP-TA2)	✓	✓		300 lbs

TRUSS ADAPTER CAD DRAWINGS

PP-TA2

PRODUCT DIMENSIONS

THE DESIGN, DETAILS, AND THIS DOCUMENT ARE THE PROPERTY OF GAMBER-JOHNSON
PAGE 1 of 1



PART NUMBER: PP-TA2	DESCRIPTION: TRUSS MOUNT FOR 11.42" TO 12" TRUSS, 2" OD TUBING	WEIGHT (LBS): 9	RATING (LBS): 200
----------------------------	---	------------------------	--------------------------

NOTES:

- SUITABLE IN ALL THREE MOUNTING POSITIONS: **HORIZONTAL, VERTICAL, AND OVERHEAD.**
- COMPATIBLE WITH 11.42" [290MM] TO 12.00" [304.8MM], TRIANGULAR AND RECTANGULAR (BOX SQUARE) TRUSS.

COMPATIBILITY:

WALL MOUNTS: CTM-MS1, CTM-MS2, CTM-MS3, PFDM2, PTDM2, SYM-IB-XXB
CEILING MOUNTS: PP-5, PP-5A, PP-6, PP-6A, AST-1321, AST-2446
PROJECTOR MOUNTS: PBC-UMS, PBC-UMW, PBL-UMS, PBL-UMW, PBM-UNI
VESA ADAPTER PLATE: UFP-280B, UFP-400

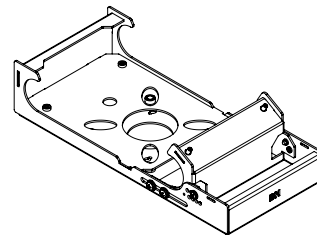
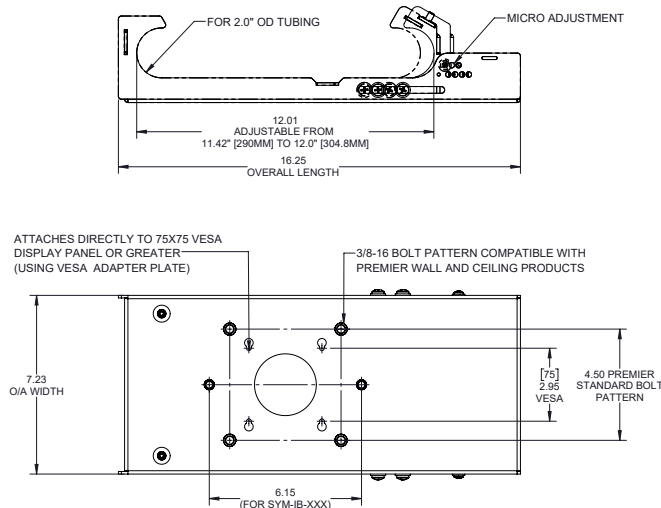

HOW TO BUY

Contact your local sales expert by scanning the QR Code below!



Questions or need more information? No problem, we're here to help!

Call us at, 1.800.368.9700
Email us at, ORDERS@PREMIERMOUNTS.COM

PREMIER MOUNTS
500 W Central Ave, Suite A
Brea, CA 92821