

PSD-S

Ceiling Mount Adapter

INSTALLATION INSTRUCTIONS



9533-025-001-00



premiermounts.com | p. 800.368.9700 | e. orders@premiermounts.com
500 W Central Ave, Suite A, Brea, CA 92821 USA

Table of Contents

Warning Statements	2
Parts List	3
Installation Tools	3
Attaching the Ceiling Adapter	4
Attaching the Mounting Plate	6
Technical Specifications	8
Warranty	9

Warning Statements



THE CEILING STRUCTURE MUST BE CAPABLE OF SUPPORTING AT LEAST FIVE TIMES THE WEIGHT OF THE DISPLAY. IF NOT, THE CEILING STRUCTURE MUST BE REINFORCED. PROPER INSTALLATION PROCEDURE BY A QUALIFIED SERVICE TECHNICIAN, AS OUTLINED IN THE INSTALLATION INSTRUCTIONS, MUST BE ADHERED TO. FAILURE TO DO SO COULD RESULT IN SERIOUS PERSONAL INJURY, OR EVEN DEATH.



DO NOT PLACE DISPLAYS WEIGHING MORE THAN 175LBS. ON THIS MOUNT. IF THIS WEIGHT IS EXCEEDED, DAMAGE TO THE MOUNT AND/OR UNIT MAY OCCUR.



PRIOR TO THE INSTALLATION OF THIS PRODUCT, THE INSTALLATION INSTRUCTIONS SHOULD BE READ AND COMPLETELY UNDERSTOOD. THE INSTALLATION INSTRUCTIONS MUST BE READ TO PREVENT PERSONAL INJURY AND PROPERTY DAMAGE. KEEP THESE INSTALLATION INSTRUCTIONS IN AN EASILY ACCESSIBLE LOCATION FOR FUTURE REFERENCE.



Indicates that the power plug is to be disconnected from the power outlet.



Contact Premier Mounts with any questions.



Safety precautions must be taken at all times.



Warning and Caution statements.



Do not install on a structure that is prone to vibration, movement or chance of impact. Failure to do so could result in damage to the flat panel display and/or damage to the mounting surface.



Do not install near heater, fireplace, direct sunlight, air conditioning or any other source of direct heat energy. Failure to do so may result in damage to the flat panel display and could increase the risk of fire.



At least two qualified people should perform the installation procedure. Injury and/or damage can result from dropping or mishandling the flat panel display.

Parts List



Note

This ceiling mount is shipped with all proper installation hardware and components. Make sure that none of these parts are missing and/or damaged before beginning installation. If there are parts missing and/or damaged, please stop the installation and contact Premier Mounts (800-368-9700).

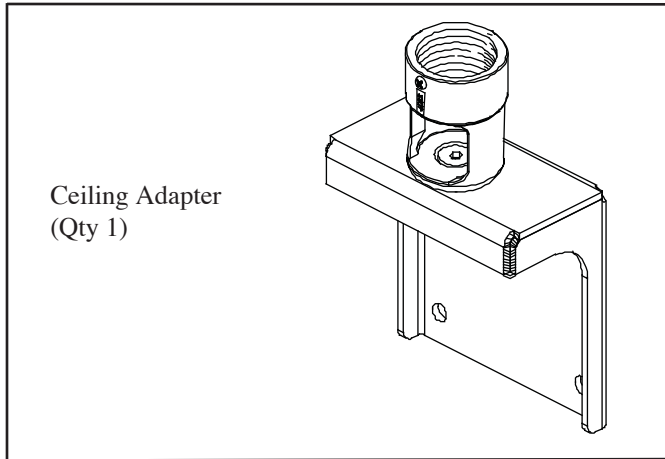

Ceiling Adapter
(Qty 1)

M10 Nut (Qty 4)

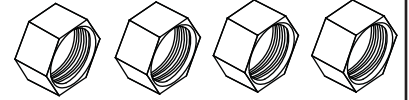

M10 Hex Head Bolt
(Qty 4)

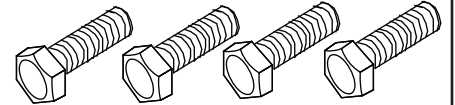

M10 Flat Washer
(Qty 8)

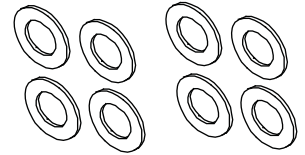

Installation Tools

Phillips Head Screwdriver

Soft Material/Blanket

Pencil

Ladder

Attaching the Ceiling Adapter



Note Before the following steps are begun, the appropriate suspension device must be installed. Premier mounts offers the AST-1321, AST-2446 or a standard 1-1/2" NPT extension pipe. Please see the installation instructions that are included with these respective mounting configurations.

Step 1. To attach the ceiling adapter to the suspension device (not included), rotate the ceiling adapter clockwise onto the suspension device a minimum of five (5) complete turns.

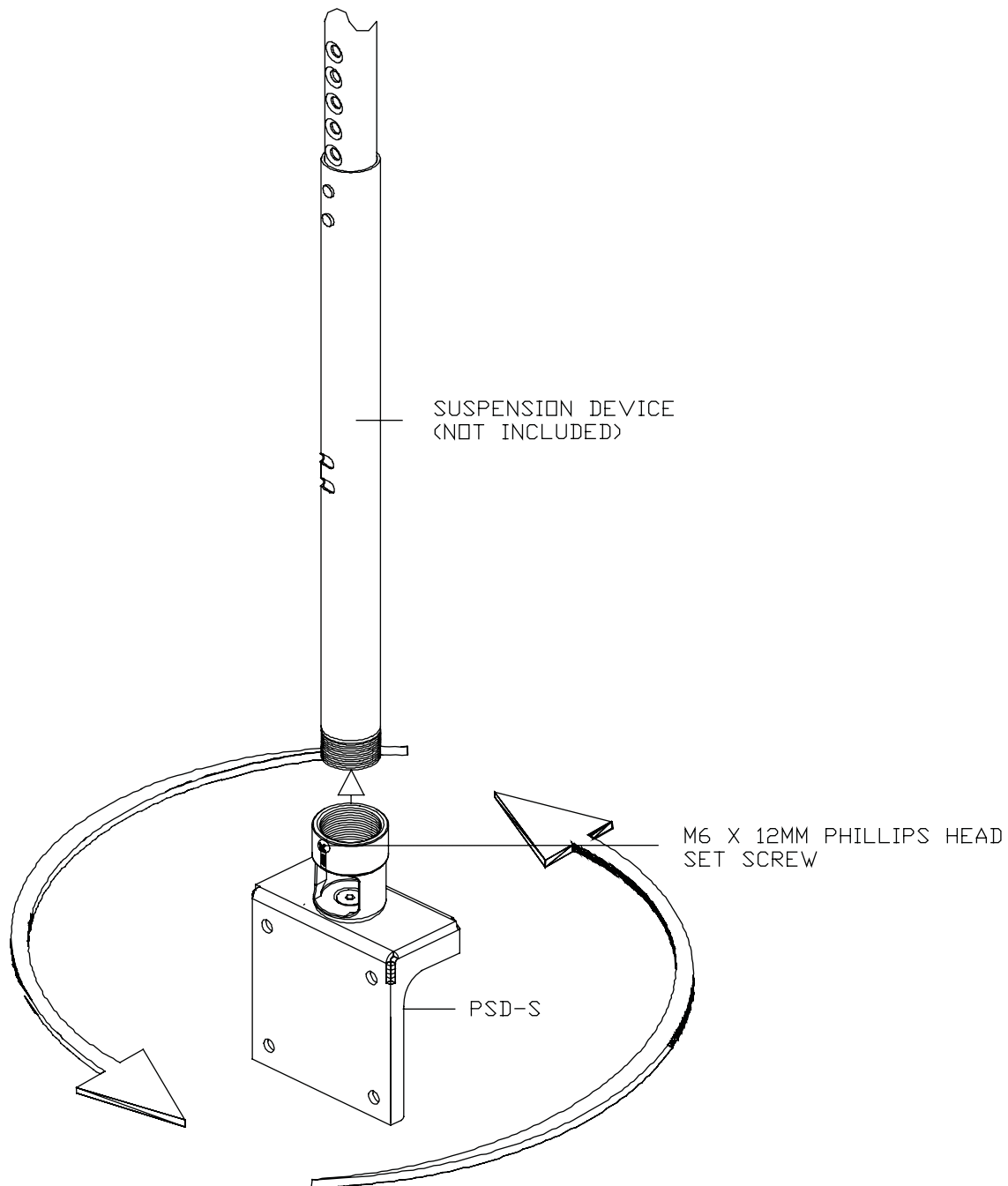



Note A Phillips head screwdriver is required to perform the following step.

Step 2. Once the ceiling adapter has been attached, tighten the M6 x 12mm Phillips head set screw using a Phillips screwdriver.

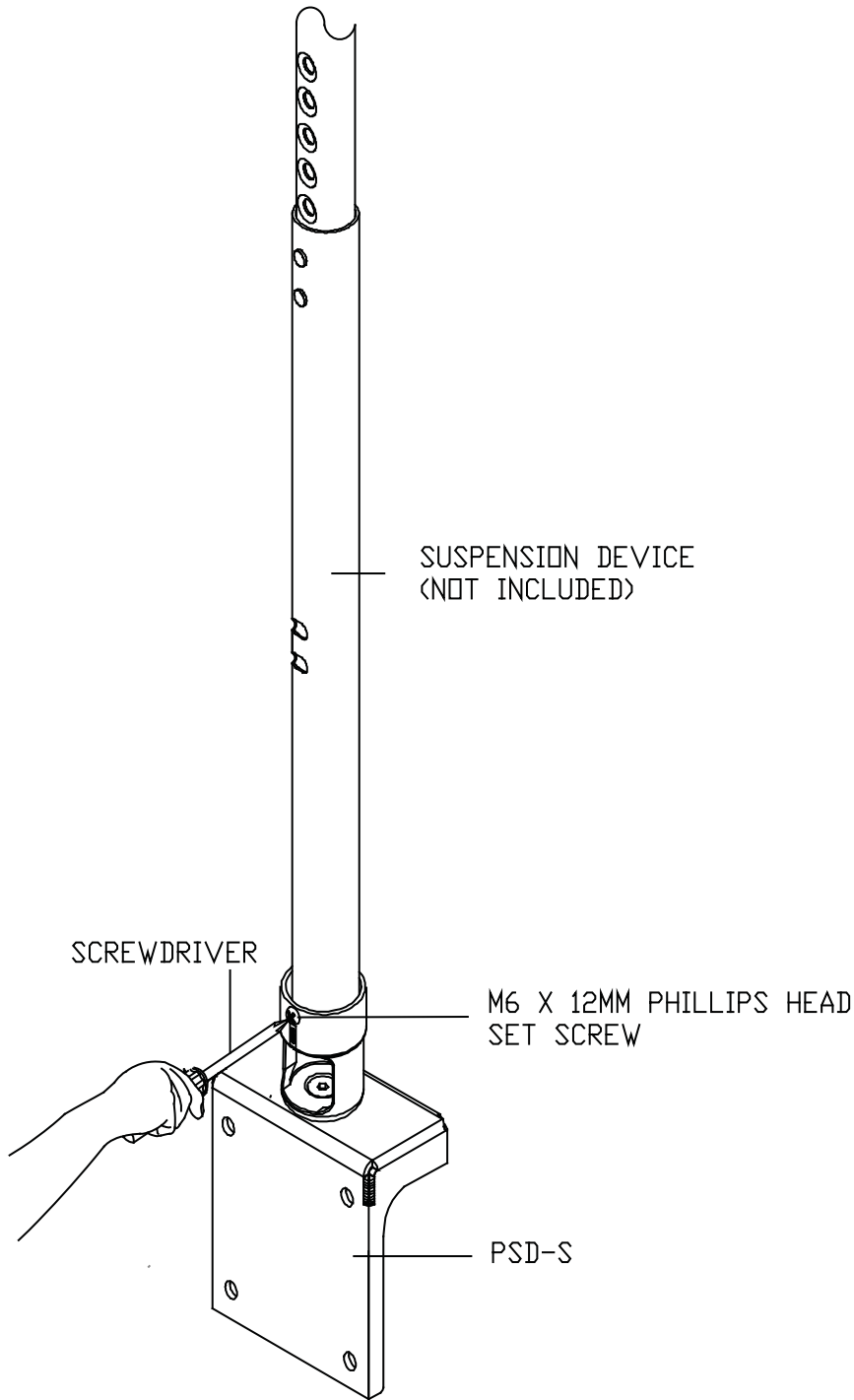

Attaching the Mounting Plate

Step 1. Use four (4) M10 hex head bolts, eight (8) M10 flat washers, and four (4) M10 nuts to attach the mounting plate to the ceiling adapter.

 **Note** At this time, finger tighten all hardware.

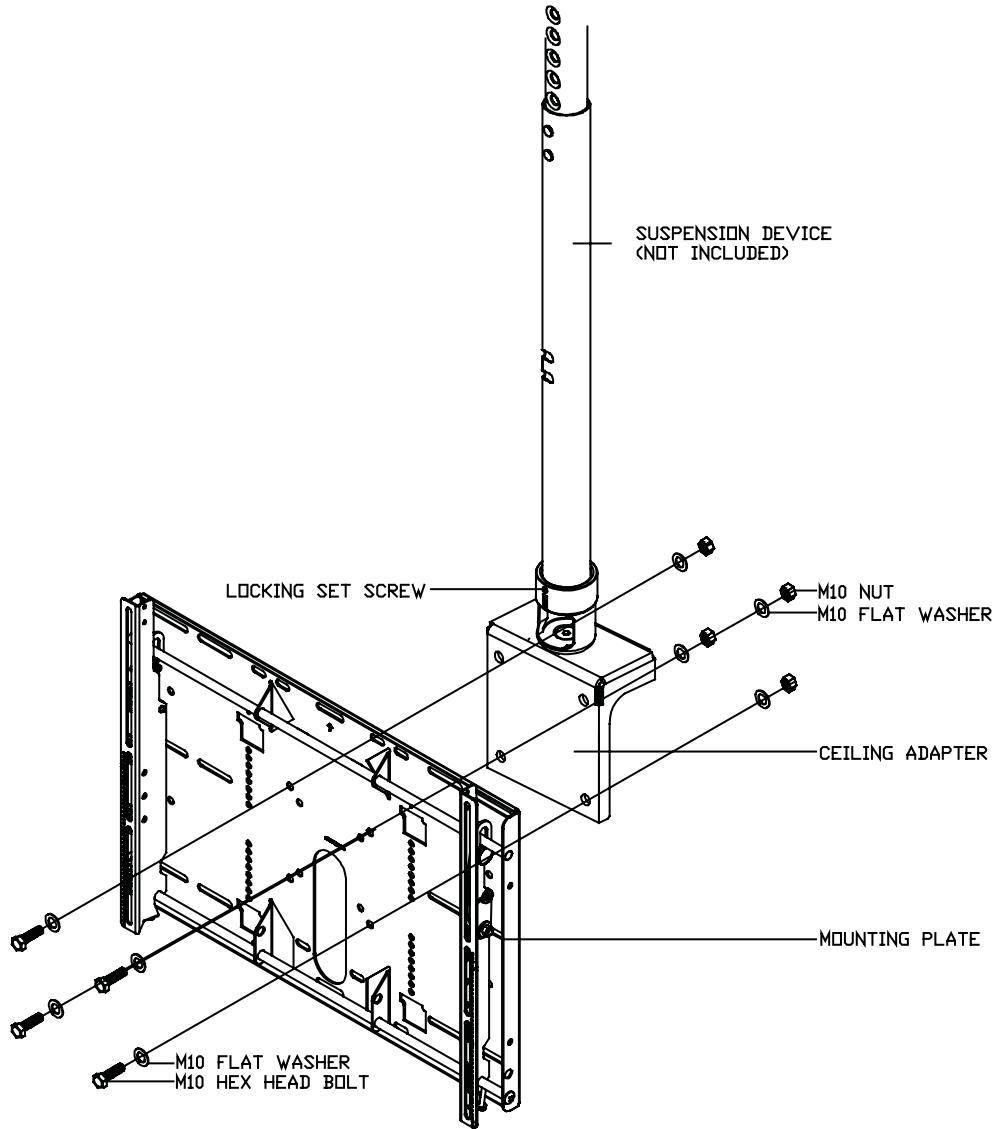



Note A 17mm open-end wrench and a 17mm socket wrench will be required to perform the following step.

Step 2. Once the both units have been attached together, use a 17mm socket wrench and a 17mm wrench to tighten the M10 hardware.

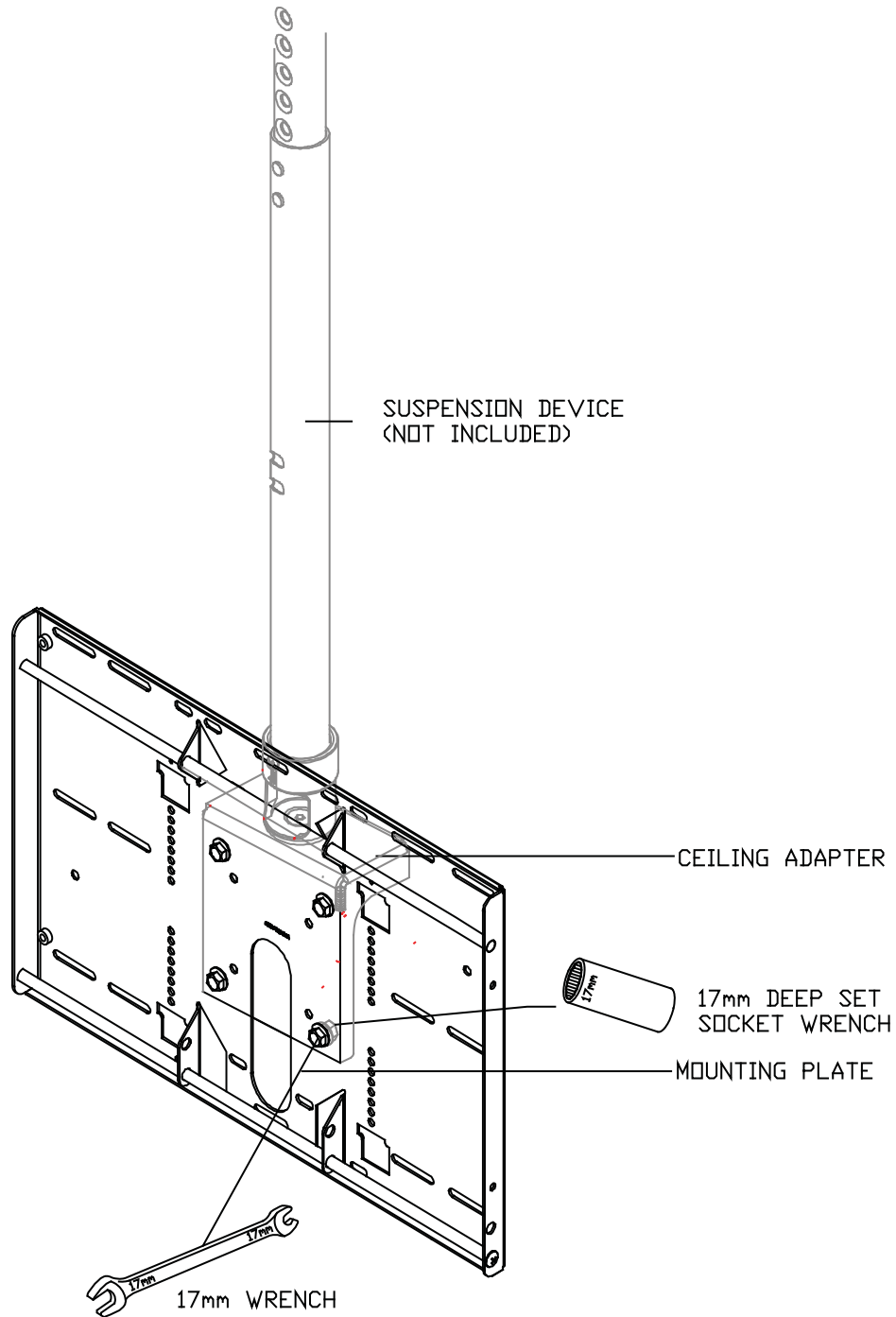

Technical Specifications

All measurements are in inches (mm).

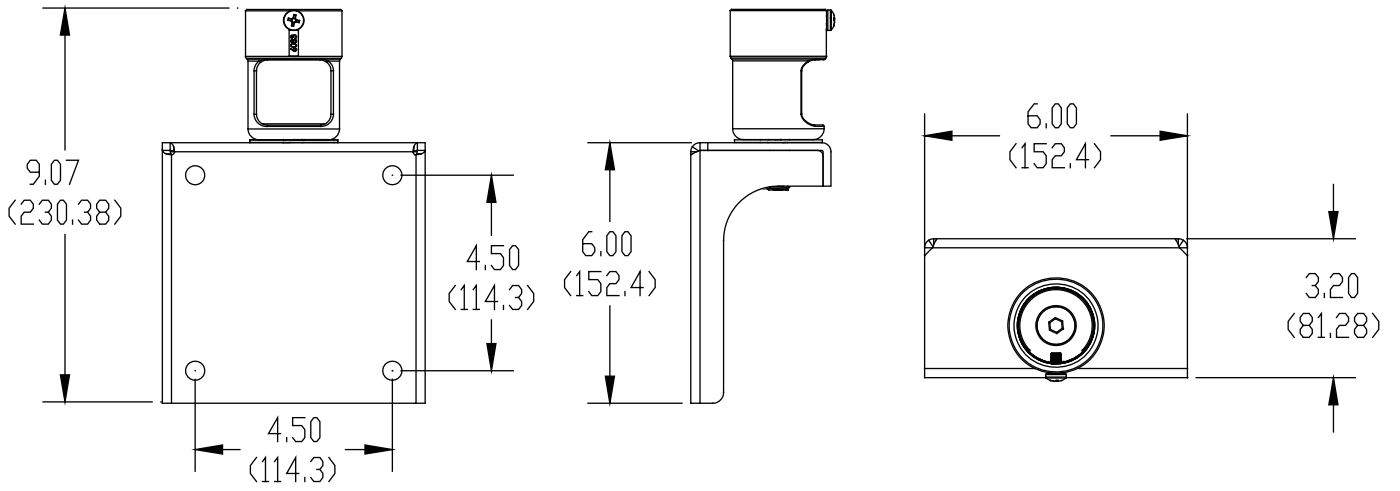

PREMIER MOUNTS
LIMITED LIFETIME WARRANTY

What and Who is Covered by this Limited Warranty and for How Long

Premier Mounts warrants this product to be free from defects in material and workmanship for the lifetime of the original owner of this product. The limited warranty is valid only for the original purchaser of the product.

What Premier Mounts Will Do

At the sole option of Premier Mounts, Premier Mounts will repair or replace any product or product part that is defective. If Premier Mounts chooses to replace a defective product or part, a replacement product or part will be shipped to you at no charge, but you must pay any labor costs.

What is Not Covered; Limitations

PREMIER MOUNTS DISCLAIMS ANY LIABILITY FOR DAMAGE TO MOUNTS, ADAPTERS, DISPLAYS, PROJECTORS, OTHER PROPERTY, OR PERSONAL INJURY RESULTING, IN WHOLE OR IN PART, FROM IMPROPER INSTALLATION, MODIFICATION, USE OR MISUSE OF ITS PRODUCTS.

PREMIER MOUNTS DISCLAIMS ALL OTHER WARRANTIES, EXPRESS OR IMPLIED, INCLUDING WARRANTIES OF MERCHANTABILITY AND FITNESS FOR A PARTICULAR PURPOSE. PREMIER MOUNTS IS NOT RESPONSIBLE FOR INCIDENTAL OR CONSEQUENTIAL DAMAGES, INCLUDING BUT NOT LIMITED TO, INABILITY TO USE ITS PRODUCTS OR LABOR COSTS FOR REMOVING AND REPLACING DEFECTIVE PRODUCTS OR PARTS. SOME STATES DO NOT ALLOW THE EXCLUSION OR LIMITATION OF INCIDENTAL OR CONSEQUENTIAL DAMAGES, SO THE ABOVE LIMITATION OR EXCLUSION MAY NOT APPLY TO YOU.

What Customers Must Do for Limited Warranty Service

If you discover a problem that you think may be covered by the warranty you **MUST REPORT** it in writing to the address below within thirty (30) days. Proof of purchase (an original sales receipt) from the original consumer purchaser must accompany all warranty claims. Warranty claims must also include a description of the problem, the purchaser's name, address, and telephone number. General inquiries can be addressed to Premier Mounts Customer Service at 1-800-368-9700. Warranty claims will not be accepted over the phone or by fax.

PREMIER MOUNTS
ATTN: Warranty Claims
500 W Central Ave, Suite A
Brea, CA 92821

How State Law Applies

THIS WARRANTY GIVES YOU SPECIFIC LEGAL RIGHTS, AND YOU MAY ALSO HAVE OTHER RIGHTS WHICH VARY FROM STATE TO STATE.

©PREMIER MOUNTS
500 W Central Ave, Suite A
Brea, CA 92821

USA & CANADA
Phone: 800-368-9700
Fax: 800-832-4888
e. orders@premiermounts.com

