

GB-AVSTOR3

Installation Guide

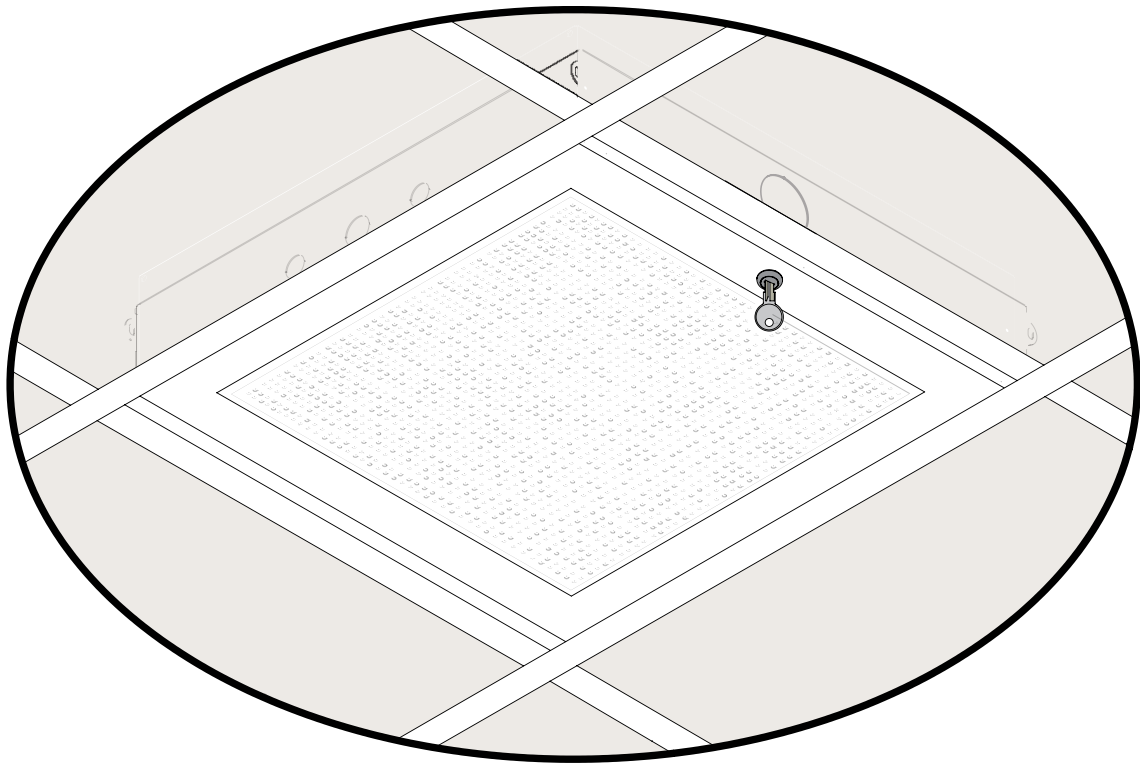

premiermounts.com | p. 800.368.9700 | e. orders@premiermounts.com
500 W Central Ave, Suite A, Brea, CA 92821 USA

GB-AVSTOR3

Installation Guide

Weight Limit

Maximum Weight: **50 lbs.**

THE CEILING STRUCTURE MUST BE CAPABLE OF SUPPORTING AT LEAST FOUR TIMES THE WEIGHT OF THE CEILING BOX. IF NOT, THE CEILING STRUCTURE MUST BE REINFORCED.

Warning Statements



PRIOR TO THE INSTALLATION OF THIS PRODUCT, THE INSTALLATION INSTRUCTIONS MUST BE READ AND COMPLETELY UNDERSTOOD. KEEP THESE INSTALLATION INSTRUCTIONS IN AN EASILY ACCESSIBLE LOCATION FOR FUTURE REFERENCE.



PROPER INSTALLATION PROCEDURE BY A QUALIFIED SERVICE TECHNICIAN MUST BE FOLLOWED, AS OUTLINED IN THESE INSTALLATION INSTRUCTIONS. FAILURE TO DO SO COULD RESULT IN PROPERTY DAMAGE, SERIOUS PERSONAL INJURY, OR EVEN DEATH.



SAFETY MEASURES MUST BE PRACTICED AT ALL TIMES DURING THE ASSEMBLY OF THIS PRODUCT. USE PROPER SAFETY EQUIPMENT AND TOOLS FOR THE ASSEMBLY PROCEDURE TO PREVENT PERSONAL INJURY.



PREMIER MOUNTS DOES NOT WARRANT AGAINST DAMAGE CAUSED BY THE USE OF ANY PREMIER MOUNTS PRODUCT FOR PURPOSES OTHER THAN THOSE FOR WHICH IT WAS DESIGNED OR DAMAGE CAUSED BY UNAUTHORIZED ATTACHMENTS OR MODIFICATIONS, AND IS NOT RESPONSIBLE FOR ANY DAMAGES, CLAIMS, DEMANDS, SUITS, ACTIONS OR CAUSES OF ACTION OF WHATEVER KIND RESULTING FROM, ARISING OUT OF OR IN ANY MANNER RELATING TO ANY SUCH USE, ATTACHMENTS OR MODIFICATIONS.



At least two qualified people should perform the assembly procedure. Personal injury and/or property damage can result from dropping or mishandling the projector.



This product is intended for indoor use only. Use of this product outdoors could lead to product failure and/or serious personal injury.



Do not install near sources of high heat. Do not install on a structure that is prone to vibration, movement or chance of impact.

Required for Installation:



Ladder



Hand Held Drill

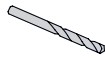

1/8" Drill Bit



1/4" Masonry Drill Bit



Protective Eyewear



Hammer

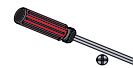

Screwdriver

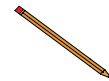

Pencil

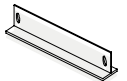

24" T-Bar

Included Components:

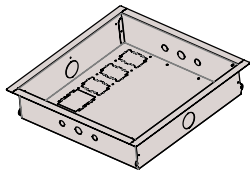

x1

Ceiling Box



x2

Key



x12

Zip Ties

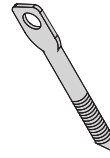

x4

1/4" x 3" Eye Lag Screws

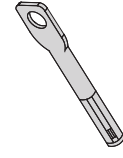

x4

M6 x 2.4" Eye Anchor Bolts

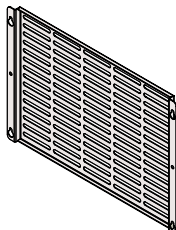

x1

Equipment Mounting Tray

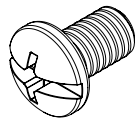

x6

M5 X 8mm Phillips Head Screw

QUICK LOCK CABLE KIT

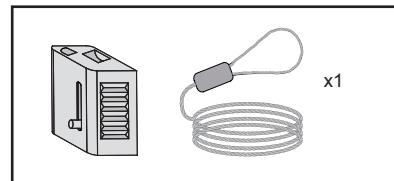

x1

1

Lid Removal

- 1) Unlock and swing open the lid.
- 2) Push the lid in and away from the metal hinges
- 3) Push the lid toward the closest edge of the ceiling box.
- 4) Pull the lid carefully out from the ceiling box.

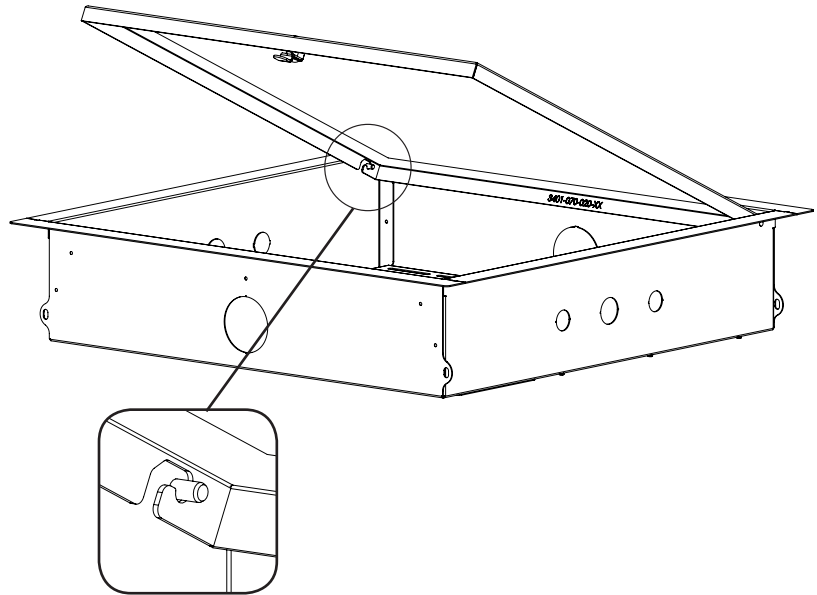

2

Removing the Electrical Knockouts (Optional)



Installation of the power must be done by an electrician.

- 1) Remove screws from around the desired electrical knockouts (Figure 1) to detach their covers.
- 2) Remove the knockout covers from the top of the GB-AVSTOR3 (Figure 2).
- 3) Remove the knockouts.



If you have opened a knockout and no longer want to use it, re-attach its cover to prevent airflow into the ceiling.

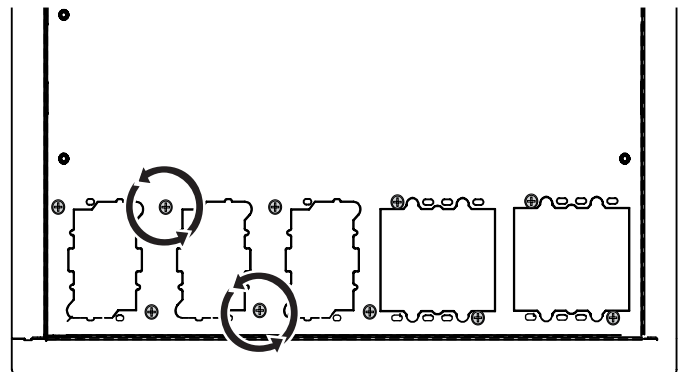

Figure 1 1- and 2-gang electrical knockouts inside the GB-AVSTOR3

Detach the knockout cover after removing its screws.

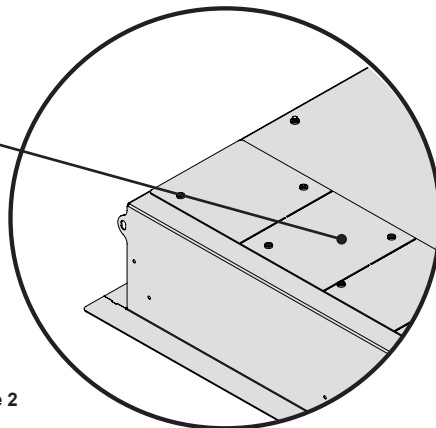

Figure 2



GB-AVSTOR3

Installation Guide

3

Ceiling Box Installation

- 1) Determine the placement of the GB-AVSTOR3.
- 2) Remove the ceiling tile where the ceiling box will be mounted.



Store the ceiling tile in a safe location in the event that it needs to be reused.

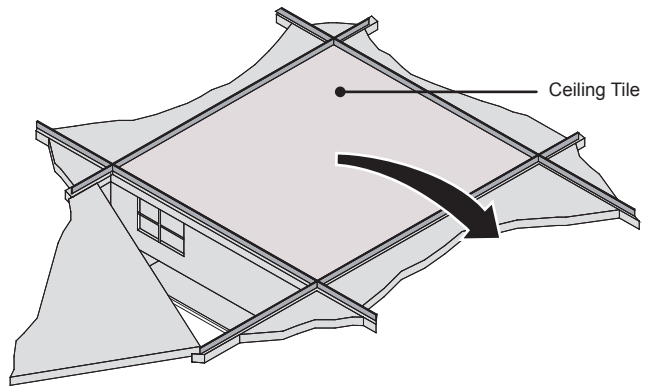

4

Ceiling Attachment

The ceiling box must be secured using the Quick Locks and 1/16" braided cables (supplied).

Wood Stud Ceiling

- 1) Determine the mounting location.
- 2) Use a 1/8" drill bit to pre-drill the mounting holes.
- 3) Secure the four (4) 1/4" eye lag screws to the wood stud in the ceiling.
- 4) Run the open end of the 1/16" braided cable through the hole in an eye lag screw.
- 5) Run the open end through the loop.
- 6) Pull the open end down until the 1/16" braided cable tightens around the eye lag screw.
- 7) Repeat steps 4-6 for the remaining three mounting points.

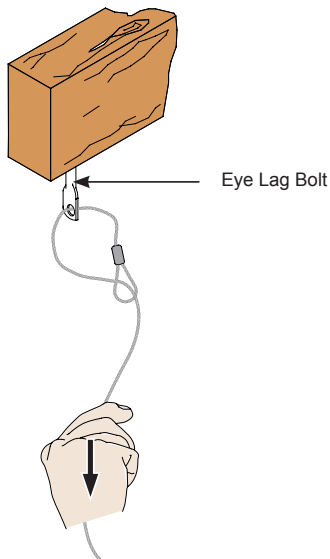

Concrete Ceiling

- 1) Determine the mounting location.
- 2) Use a 1/4" concrete drill bit to drill the mounting holes.
- 3) Place the concrete eye anchor bolts into the pre-drilled holes and gently tap into place using a rubber mallet or hammer.
- 4) Run the open end and 1/16" braided cable through the hole in an eye anchor bolt.
- 5) Run the open end through the loop.
- 6) Pull the open end down until the braided cable tightens around the eye anchor bolt.
- 7) Repeat steps 4-6 for the remaining three mounting points.

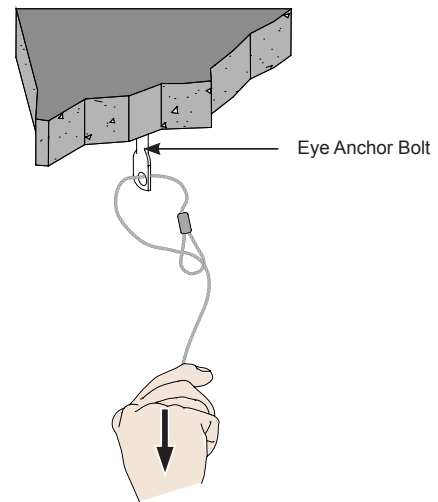

5

Truss Ceiling

- 1) Loop the braided cable around the truss.
- 2) Run the open end 1/16" braided cable through the loop.
- 3) Pull the open end down until the 1/16" braided cable tightens around the truss.
- 4) Repeat steps 1-3 for the remaining three mounting points.

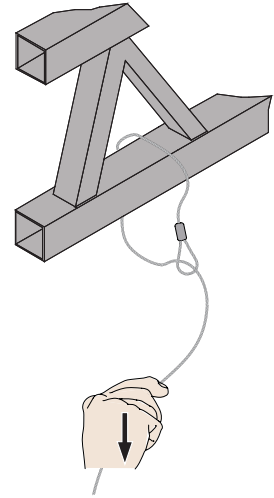

6

Quick Lock Operation

Please follow the steps below in numerical order 1, 2, 3, and 4 to correctly install the Quick Lock Cable Kit.

 To Release or relieve tension on the 1/16" braided cable, slide the release pin to disengage.

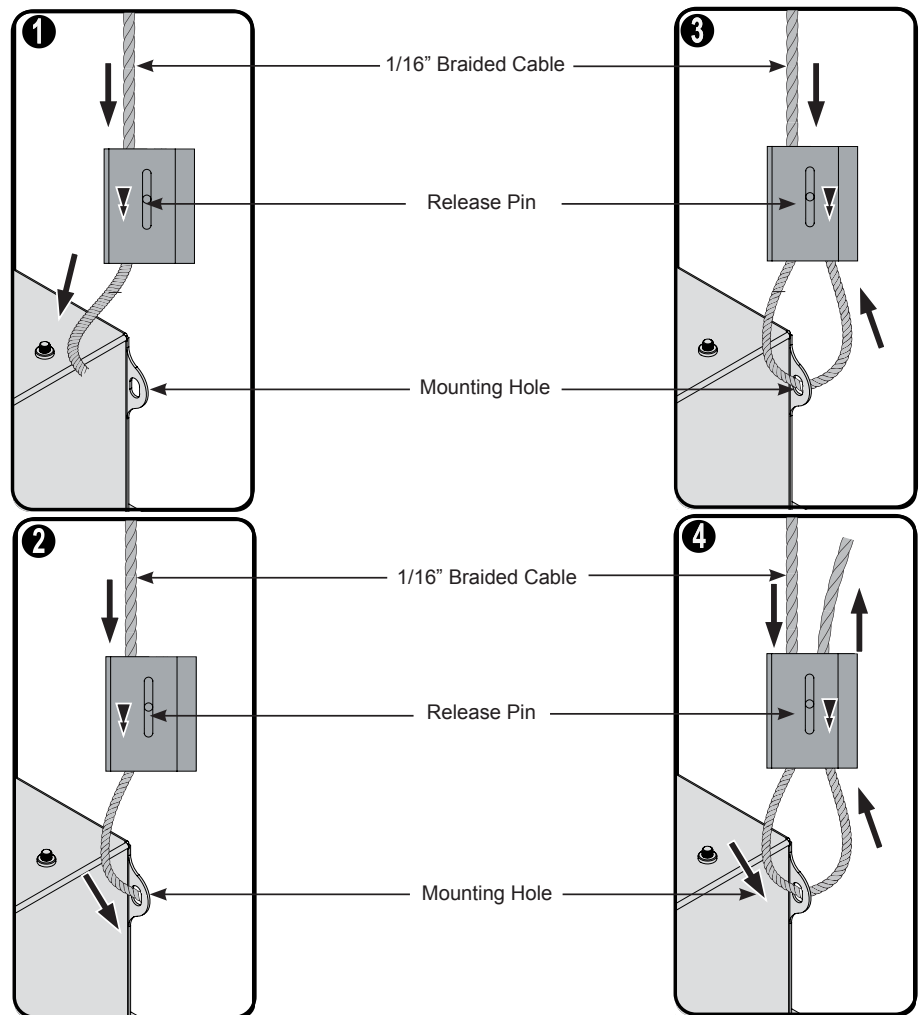
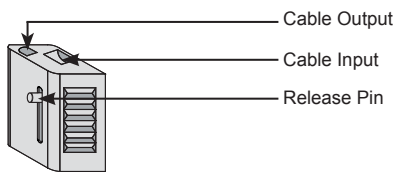

GB-AVSTOR3 Installation Guide

7



It is recommended that the following steps be performed by two people.

- 1) Lift the ceiling box from the exposed ceiling framework until the ceiling box's outer lip rests against the bottom of the ceiling framework (Figure 1).
- 2) Adjust the 1/16" braided cable tension, but do not over tighten.



When adjusting the tension of the weight-bearing side of the Quick Lock, the 1/16" braided cable must be pulled through the Quick Lock until the desired tension is attained.

- 3) When you have the desired tension, pull the 1/16" braided cable through the other side of the Quick Lock.



Once the tension has been adjusted, be sure that there a minimum of 6" of excess 1/16" braided cable on the non-weight bearing side of the Quick Lock (Figure 2).

- 4) Use cable cutters to remove any remaining 1/16" braided cable (optional).



If you installing the GB-AVSTOR3 through a 24" x 48" ceiling tile opening, attach a 24" T-bar frame (commercially available) in the 24" x 48" ceiling tile frame for support and place a 2' x 2' ceiling tile adjacent to the GB-AVSTOR3 (Figures 3 and 4).

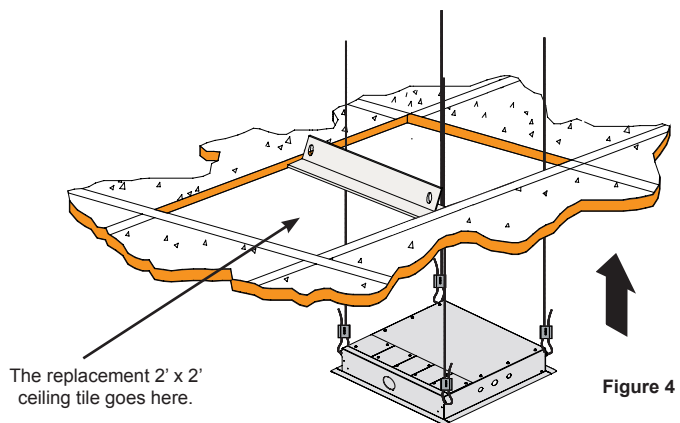
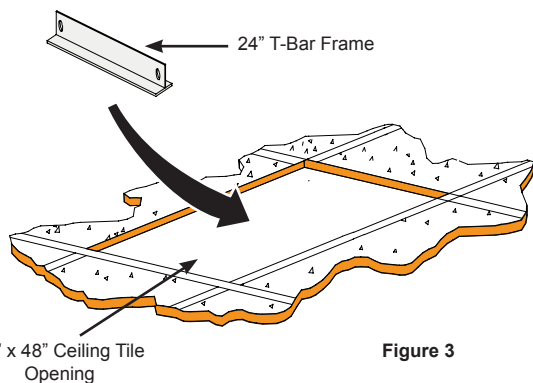
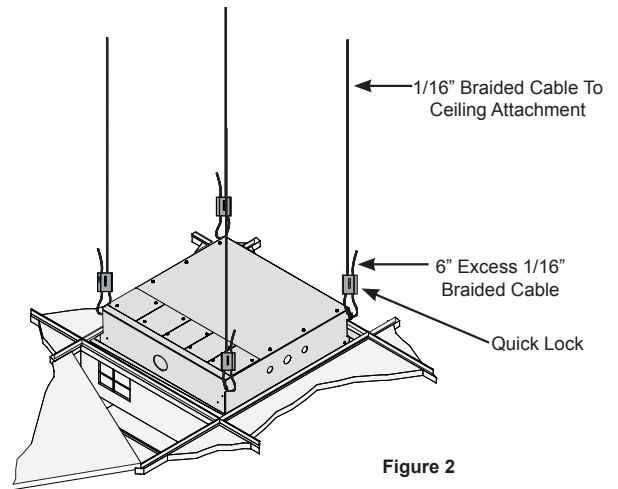
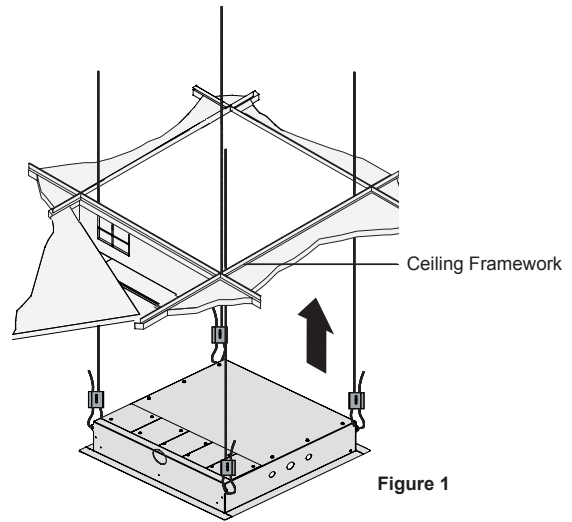

8

Attaching Equipment to the Tray

- 1) Place your electronic components onto the mounting tray.
- 2) Align the electronic components so that the weight is distributed as evenly as possible.
- 3) Run the zip ties through the mounting slots on the tray, underneath the mounting tray and up through the mounting slot on the other side of the electronic component.
- 4) Tighten the zip tie down and cut off any excess zip tie.



As a reminder, small screws and flat washers may also be used to attach electronic components to the grid.

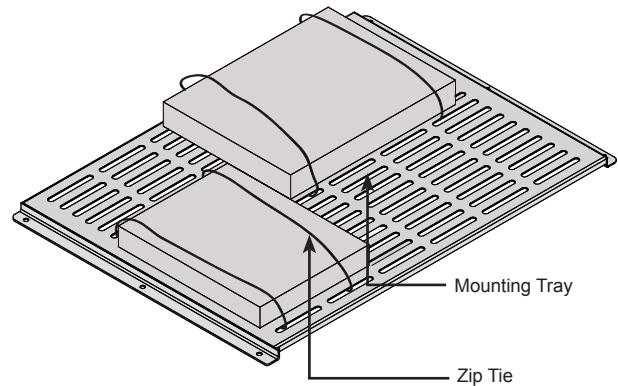

9

Attaching the Mounting Tray to the GB-AVSTOR3

- 1) Insert four (4) M5 x 8mm Phillips head screws loosely into the outer holes inside the GB-AVSTOR3 (Figure 1).
- 2) Place the mounting tray into the middle section of the GB-AVSTOR3 (Figure 2).
- 3) Hook the mounting tray onto the heads of the M5 x 8mm Phillips head screws on the GB-AVSTOR3 (Figure 3).
- 4) Insert two (2) M5 x 8mm Phillips head screws into the middle mounting holes of the mounting tray.
- 5) Use a Phillips tip screwdriver to tighten all six (6) screws.



Do not over tighten the mounting screws.

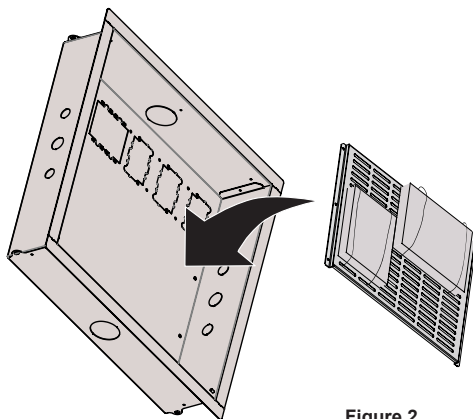

Figure 2

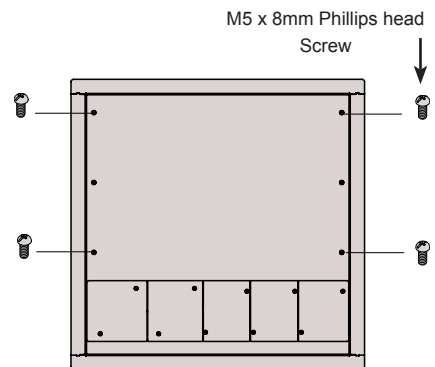

Figure 1

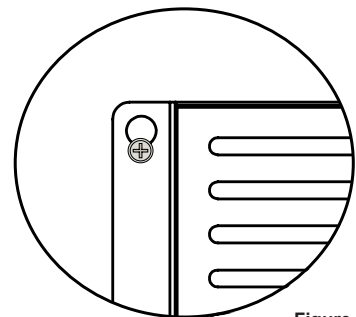

Figure 3



GB-AVSTOR3

Installation Guide

10

- 1) Re-attach the ceiling box lid to the ceiling box.
- 2) Swing the ceiling box lid up into place.

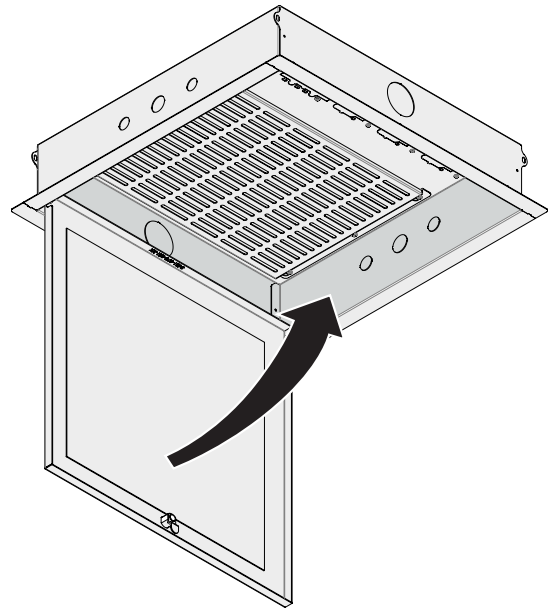

11

- 1) Hold the lid in place.
- 2) Use a key (supplied) to lock the lid in place.
- 3) Do not release the ceiling box lid until you are sure that the lock has been engaged and the lid is secure.

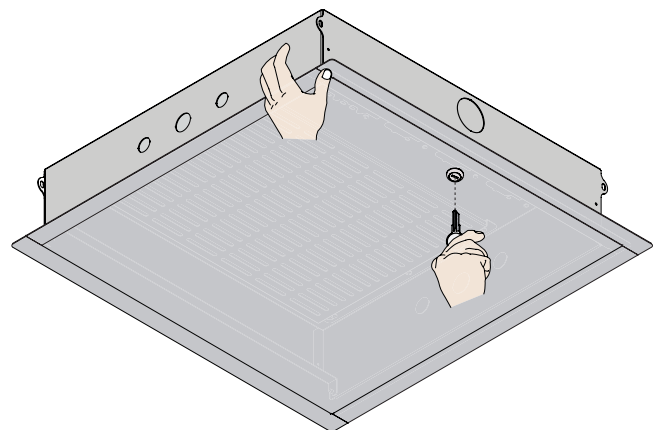
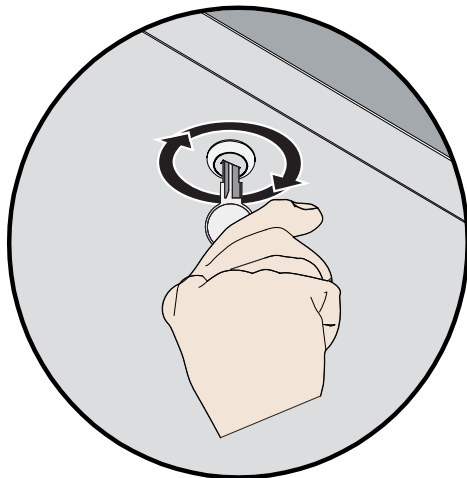

PREMIER MOUNTS LIMITED LIFETIME WARRANTY

What and Who is Covered by this Limited Lifetime Warranty

Premier Mounts warrants all mounting products to be free from defects in material and workmanship for the lifetime of the original installation of the product.

What Premier Mounts Will Do

At the sole option of Premier Mounts, Premier Mounts will repair or replace any product or product part that is defective. If Premier Mounts chooses to replace a defective product or part, a replacement product or part will be shipped to you at no charge, but you must pay any related labor costs.

What is Not Covered: Limitations

Premier Mounts disclaims any liability for damage to mounts, adapters, displays, projectors, other property, or personal injury resulting, in whole or in part, from improper installation, modification, use or misuse of its products.

NOTWITHSTANDING ANYTHING TO THE CONTRARY IN THIS WARRANTY, THIS WARRANTY IS LIMITED TO FIVE YEARS FROM THE DATE OF PURCHASE IN THE EVENT THAT THE WARRANTED PRODUCT IS COMMERCIALY RENTED OUT.

Electrical products and components, such as amplifiers, speakers, motors, switches remote controls and related electrical items, are backed by a 3-year warranty.

Premier Mounts disclaims all other warranties, express or implied, including warranties of merchantability and fitness for a particular purpose. Premier Mounts is not responsible for incidental or consequential damages, including but not limited to, inability to use its products or labor costs for removing and replacing defective products or parts. Some states do not allow the exclusion or limitation of incidental or consequential damages, so the above limitation or exclusion may not apply to you.

What Customers Must Do for Warranty Service

If you discover a problem that you think may be covered by the warranty, you must report it in writing to the address below within thirty (30) days. Proof of purchase (an original sales receipt) from the original consumer purchaser must accompany all warranty claims. Warranty claims must also include a description of the problem, the purchaser's name, address, and telephone number. General inquiries can be addressed to Premier Mounts Customer Service at 1-800-368-9700. Warranty claims will not be accepted over the phone or by fax.

PREMIER MOUNTS

ATTN: Warranty Claims

500 W Central Ave, Suite A
Brea, CA 92821

How State Law Applies

This warranty gives you specific legal rights, and you may also have other rights which vary from state to state.

Premier Mounts intends to make this manual accurate and complete. However, Premier Mounts makes no claim that the information contained herein covers all details, conditions or variations, nor does it provide for every possible contingency in connection with the installation or use of this product. The information contained in this document is subject to change without notice or obligation of any kind. Premier Mounts makes no representation of warranty, expressed or implied, regarding the information contained herein. Premier Mounts assumes no responsibility for accuracy, completeness or sufficiency of the information contained in this document.

©PREMIER MOUNTS

500 W Central Ave, Suite A
Brea, CA 92821

USA & CANADA

Phone: 800-368-9700
Fax: 800-832-4888

e. orders@premiermounts.com

