

Model: **ECM-D70T**

Weight Capacity: 175 lb./79.5 kg Per Head

Features

- 1 Holds two flat panel displays in portrait or landscape orientation
 - 2 15° of tilt facilitates strategic placement of the flat-panel
 - 3 Mount displays right out of the box with no adapters needed
- Integrated cable management keeps installation clean and organized
 - Lateral shift allows for a variety of display sizes and mounting patterns
 - 360° swivel with 2" NPT coupler
 - Works with optional brackets for mini PCs and digital media player adapters

The ECM Ceiling Mount for Dual Flat Panels features side by side flat panel mounts, which hold displays in either portrait or landscape orientation with a weight capacity up to 175 lb./79.5 kg per head. It offers dynamic viewing with 360° swivel and 15° of tilt, and fits a 2 in. NPT extension pipe. The mount's ultra-thin design keeps the center of gravity close to the flat panels for better balance. Integrated cable management keeps the installation clean and organized. Optional brackets are available for attaching mini PCs and digital media players and servers.

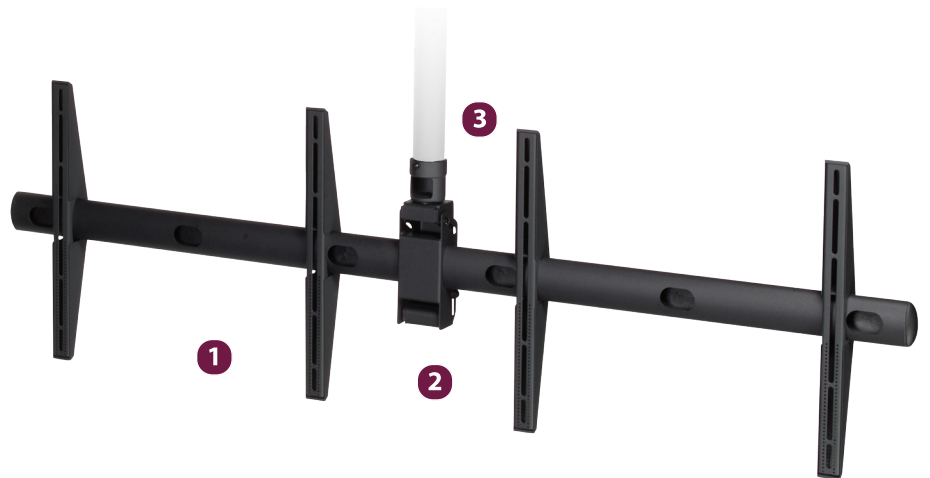

ECM-D70T supports two side by side flat panels with a total weight capacity of 350 lb.



Works with ECM-MAC2 Series Adapter for Mac mini™



Features cable routing for a clean, organized look

Ceiling Mount for Dual Flat Panels up to 175 lb./79.5 kg

ECM-D70T



Specifications

Color Black	Weight 48 lb. 21.8 kg	Weight Capacity / Mount 175 lb. 79.5 kg	Mounting Pattern 200 x 200 mm (Min) - 782 x 506 mm (Max)
Width x Height x Depth 71.2 x 21.32 x 3.34 in. 1809 x 541 x 85 mm		Total Weight Capacity 350 lb. 159.1 kg	Warranty Lifetime

Packaging

Width x Height x Depth 75 x 18 x 5 in. 1905 x 457 x 127 mm	Contents ECM Molding Covers (x2), Weldment Support Bracket (x2), ECM Mount Assembly (x1), Hardware Pack (x1)
--	--

Accessories

 <p>Ceiling Adapter with 2 inch Welded Coupler PP-6</p>	 <p>Ceiling Adapter with 2 inch Swiveling Coupler PP-6A</p>
---	---

Architectural Drawing

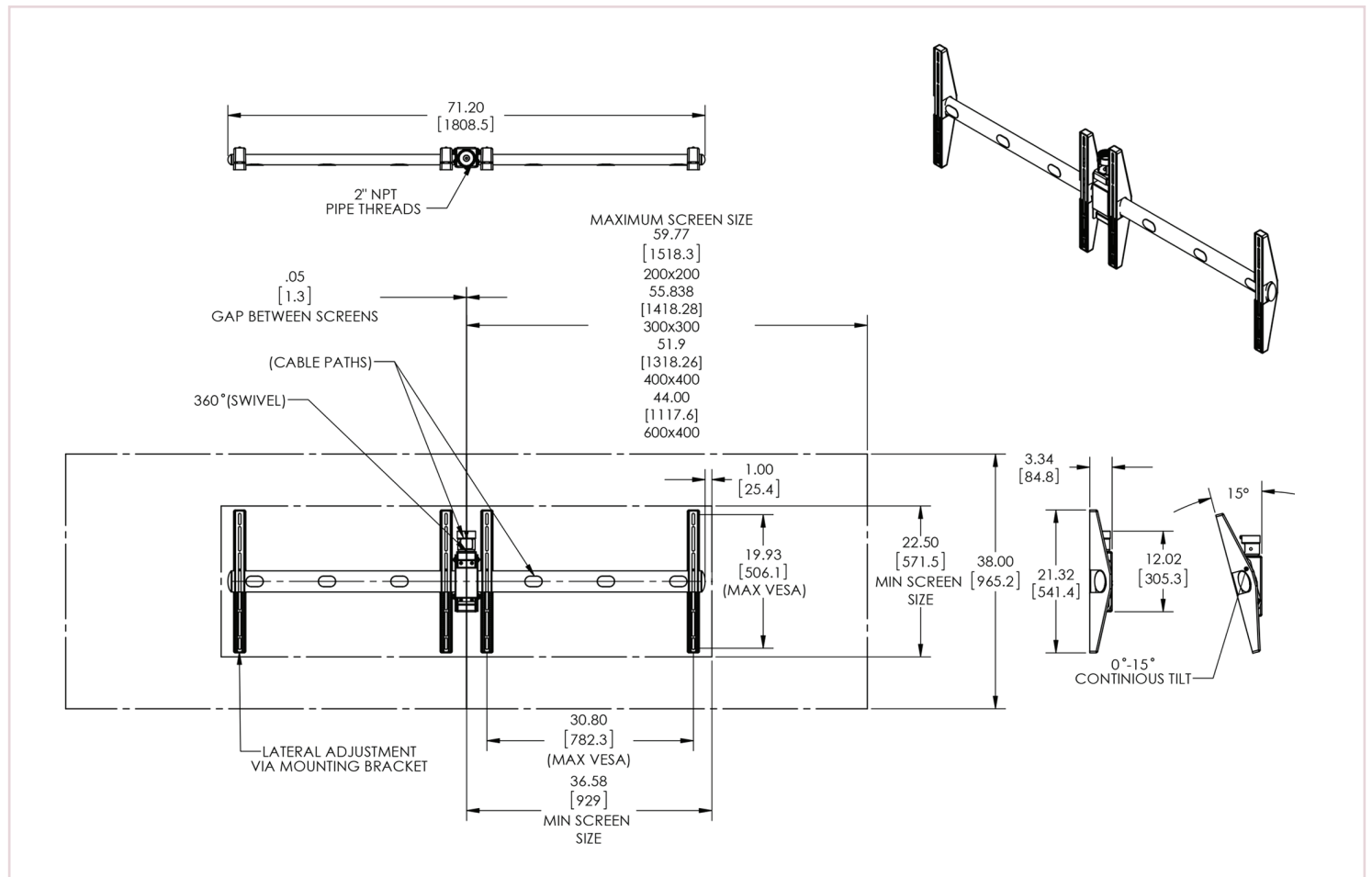

Specifications subject to change without notice